

peass schlafhorst
PPW-A

Peass Industrial Engineers Ltd.

Precision Assembly Winder
Strong heart of twisting

Precision Propeller Assembly Winder PPW-A

Assembly winding is heart of twisting. The Hi-Tech PPW-A model provides a perfect feed package to twisting machines ensuring highest productivity and best quality.

With precision winding you have following advantages:

Quality

- Less hairiness increase
- Zero split ends
- Zero patterning and ribboning zones
- More knotless yarn lengths
- Perfect unwinding properties

Productivity

- Higher speeds of upto 1600m/min
- Less breakages on TFO
- Longer running time of TFO
- Improved efficiency of TFO



Straight Yarn Path

- Gentle handling of yarn
- Ceramic contacts
- Self threading

Salient Features

- Individual spindle drive
- Individual inverter control
- Individual length measuring
- Individual diameter control
- Motorized tension device
- Electronic non-contact yarn sensors
- Cutter mechanism for single end prevention

- Diameter Control
- Swing Arm
- Yarn Laying By Counter Rotating Propeller
- Visual Display Of Yarn Break And Full Doff

- Cutter Mechanism
- Motorized Tension Device
- Electronic Non-Contact Yarn Detector
- Balloon Breaker
- Supply Package
- Separator

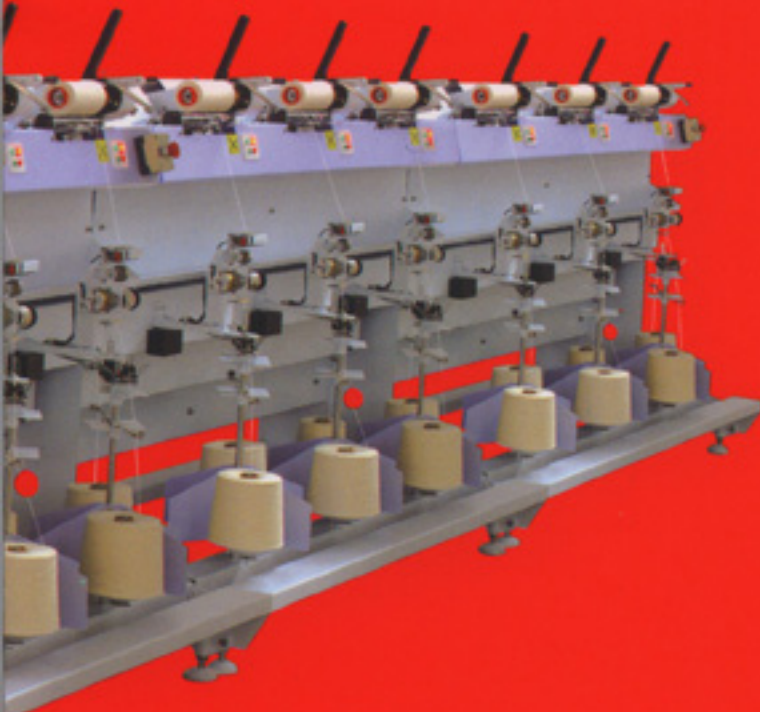
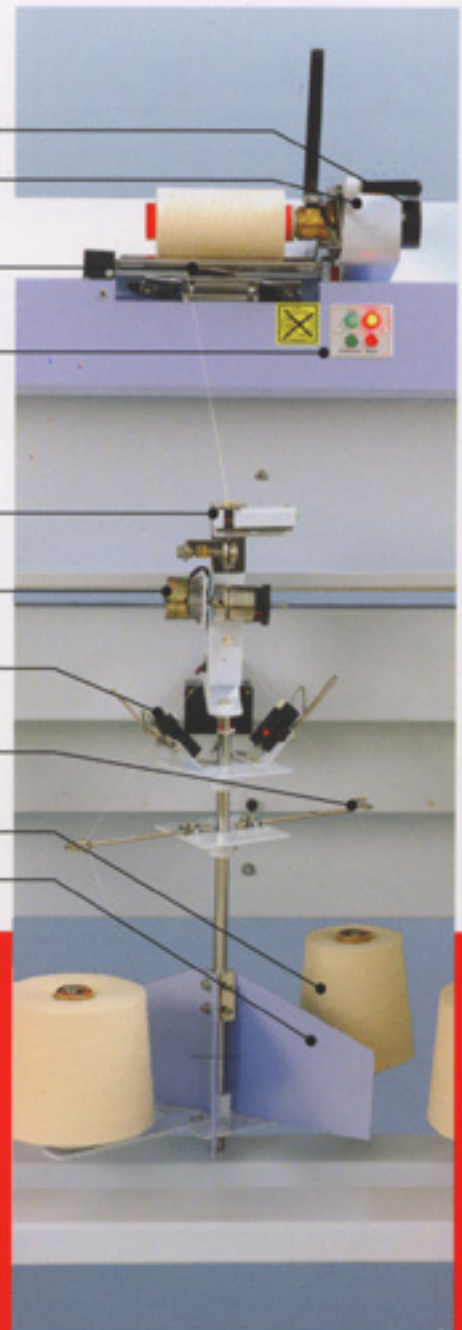

Yarn Traversing System

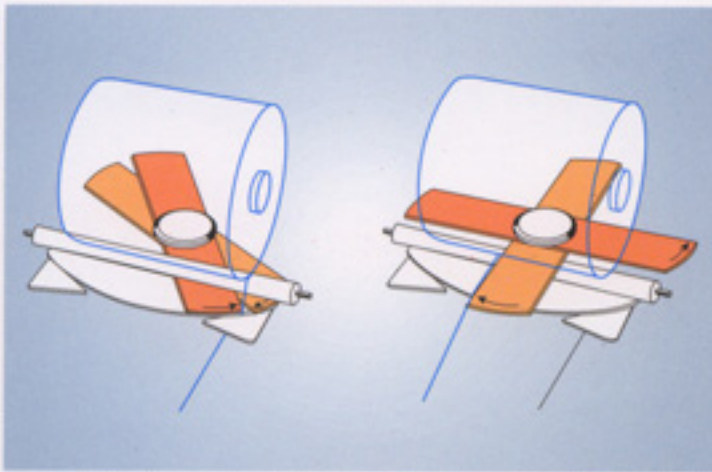

The winding system is outlined by a unique yarn laying principle. Two counter rotating propellers impart gentle handling of the yarn and a highly precise yarn laying pattern.

As the blades are directly synchronised with the positively driven yarn package, precision winding is achieved. Because of a constant winding ratio from start to the final

package diameter, absolutely no ribbon or pattern zone is observed on the produce package. This guarantees excellent unwinding characteristics of the package during the subsequent process.

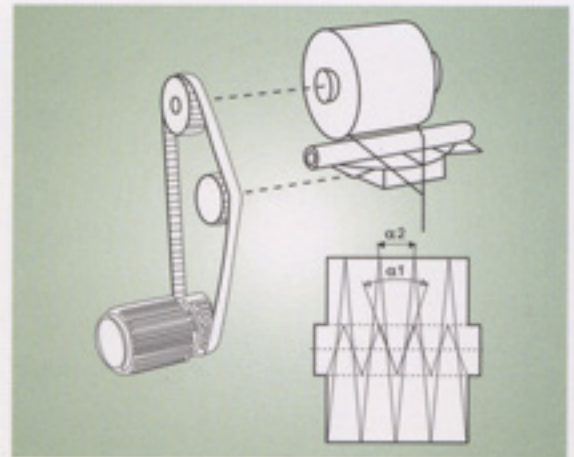

Constant number of coils from start to final package

Smart Controller

All spindle functions are monitored and controlled by the microprocessor based system which has features like :

- High definition colour LCD, TFT display
- Individual/ group wise speed & length setting
- Key-pad with 16 keys
- Storage of last 50 shift's data
- Extendable up to 96 spindles
- Individual spindle maintenance mode

Standard Features

- Individual frequency inverter drive
- Constant yarn speed by electronic control
- Auto yarn length controlling device
- Auto stop motion for full doff with visual display
- Motorized tension device
- Diameter control
- Cutter mechanism for single end prevention



Optional Features

- Overhead travelling blower
- Splicer unit
- Digital tensioner

Technical Specifications

MACHINE MODEL	PPW - A
NO. OF WINDING HEADS	3 TO 96
MACHINE ARRANGEMENT	SINGLE SIDED
SPINDLE GAUGE	500 mm
TYPE OF WINDING	PRECISION WINDING
COUNT RANGE	Nm 1 TO 200; Ne 0.60 TO 120; tex 1000 TO 5
PACKAGE DESTINATION	TWISTING
WINDING SPEED	1600 mpm (Depending on process parameters)
SUPPLY PACKAGE TYPE	ALL TYPES
PRODUCE PACKAGE TYPE	CYLINDRICAL
PRODUCE PACKAGE DIA	MIN ID Ø38 / MAX OD Ø280 mm
PRODUCE PACKAGE TRAVERSE	6" or 8"
SUPPLY PACKAGE	OD Ø250 mm
POWER (INSTALLED: 0.5 HP/ SPINDLE)	CONSUMED: 90-110 WATTS PER SPINDLE (Depending on process parameters)
SPINDLE DRIVE	INDIVIDUAL
SPECIAL FEATURES	PROPELLER THREAD LAYING SYSTEM FOR LOWEST YARN STRESSING WHILE WINDING.

Machine Dimensions

No. of spindles	3	6	9	12	15	18	21	24	27	30	33	36	39	42	45	48	66	96
Length (F-1625 mm)	2125	3750	5375	7000	8625	10250	11875	13500	15125	16750	18375	20000	21625	23250	24875	26500	36250	52500
Width in (mm)	1130																	
Height in (mm)	1350																	
Connected Load (H.P.)	1.5	3	4.5	6	7.5	9	10.5	12	13.5	15	16.5	18	19.5	21	22.5	24	33	48
Net weight in kg.	400	800	1200	1600	2000	2400	2800	3200	3600	4000	4400	4800	5200	5600	6000	6400	8800	12800

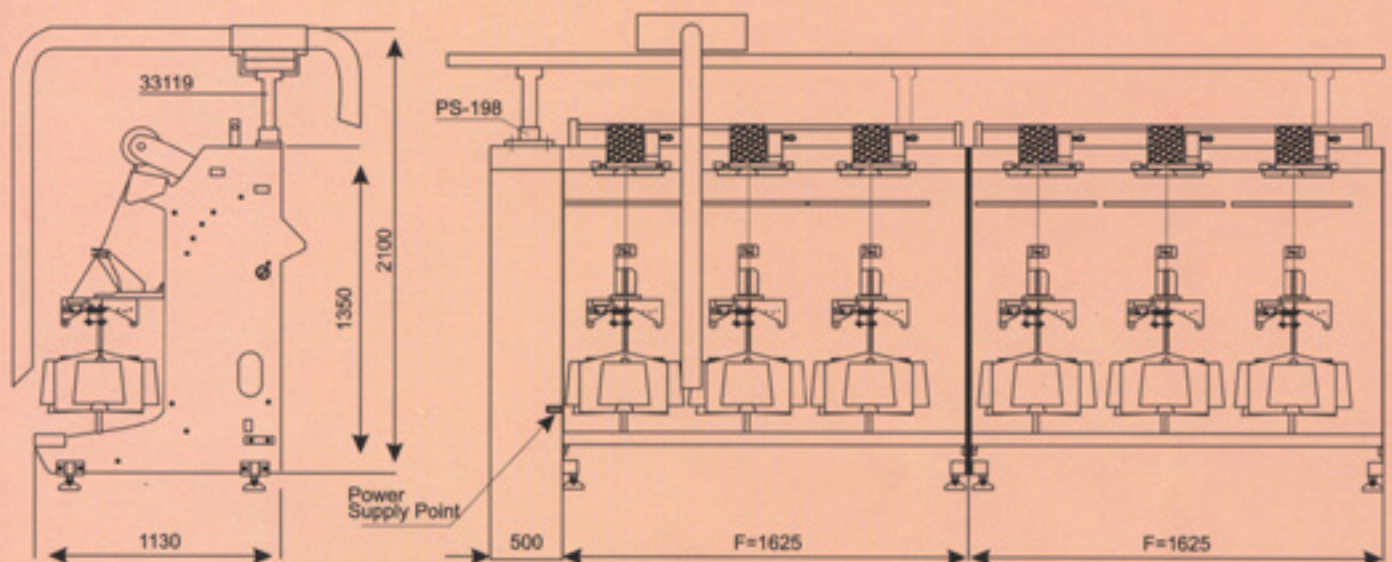

Regd. Office:

Post Box No. 128, Maneklal Road,
Navsari - 396 445 (W.R.) Gujarat, INDIA
Phone: 240843 / 250811 / 325101 / 329419
Fax: 91-2637-257321
E-mail: navsari@peass.com

Mumbai Office:

Merchant Chambers,
2nd Floor, 41, New Marine Lines,
Mumbai - 400 020 INDIA
Phone: 6631 0561 (3 Lines)
3254 5106 / 3253 5107 / 3253 5108
Fax: 91-22-6631 0570
E-mail: mumbai@peass.com

Delhi Office:

729, Pocket 'E',
Mayur Vihar Phase II,
Delhi - 110 091 INDIA
Phone: 2277 3701 / 3244 5102 / 03
Fax: 91-11-2277 4741
E-mail: delhi@peass.com

Coimbatore Office:

P-1, 3rd Floor, Red Rose Plaza,
509, D.B. Road, R.S. Puram,
Coimbatore - 641 002 INDIA
Phone: 2544097 / 3245115
Fax: 91-422-254 4097
E-mail: cbe@peass.com

Ahmedabad Office:

Samudra, B-201, 2nd Floor,
Sardar Patel Nagar Road,
Navrangpura,
Ahmedabad - 380 006 INDIA
Phone: 26427665 / 32935112
Fax: 91-79-2642 7665
E-mail: ahd@peass.com



Peass Industrial Engineers Ltd.

Website: www.peass.com