

Technical Specification

| | | |
|---|----------------|--------|
| Machine type: | | MM3-OH |
| Weight of yarn per charge | Kg | 3 |
| Duration of each working operation | Sec | 270 |
| Production per hour | Kg | 40 |
| No. of attendants | | 1 |
| Normal hank length | cm | 137.1 |
| Maximum stretched length | cm | 146 |
| Minimum shrunk length | cm | 120 |
| Minimum distance apart of hank rollers while charging | cm | 25.4 |
| Maximum stretching force | Kg | 18000 |
| Maximum squeezing pressure | Kg | 3200 |
| Charging length of rollers | cm | 110 |
| Linear pressing | Kg/cm | 29 |
| Consumption of lye (Na OH 100%/Kg) | Grams | Ca.330 |
| Consumption of hot water | L/h | 1500 |
| Consumption of cold water | L/h | 700 |
| Power required | kw | 2.2 |
| Net weight | Kg | 4350 |
| Gross weight | | 5200 |
| Volume | m ³ | 10.7 |

Control Panel





Peass Industrial Engineers Ltd.

MM3-OH

HYDRAULIC HANK YARN MERCERIZING MACHINE



Regd. Office & Works:

Post Box No. 128, Maneklal Road,
Navsari - 396 445,
(W.R.) Gujarat, India.
Phone: 50811 (4 Lines), Gram: PEASS
Fax: 02637-57321.
Email: navsari@peass.com

Mumbai Office:

Merchant Chambers, 2nd Floor,
41, New Marine Lines, Mumbai - 400 020, India.
Phones: 022-231 0561 (6 Lines),
Fax: 91-22-231 0570.
E-mail: mumbai@peass.com

Delhi Office:

729, Pocket E, Mayur Vihar Phase II,
Delhi-110 091, India.
Phone: 277 3701 / 277 2859.
Gram: PEASSDEL
Fax: 91-11-277 4741 / 277 2859.
E-mail: peass.del@psindia.com

Coimbatore Office:

P-1, 3rd Floor, Red Rose Plaza,
509, D. B. Road, R. S. Puram,
Coimbatore - 641 002, India.
Phone: 544 097 / 556 830.
Fax: 91-0422-544 097.
E-mail: cbe@peass.com

Ahmedabad Office:

Samudra, B-201, 2nd Floor,
Sardar Patel Nagar Road,
Navrangpura, Ahmedabad - 380 009, India.
Phone: 642 7665 / 656 2548.
Fax: 079 - 642 7665.
E-mail: peass.ahd@psindia.com

* The technical details of the above machines are subject to change with constant upgradation.

Hydraulic Hank Yarn Mercerizing Machine

PEASS-YARN MERCERIZING MACHINE MODEL: MM3-OH

The latest version of Peass automatic hank mercerizing machine contains a number of interesting features and is a single-ended machine. The stretching devices consist of a pair of solid rollers running in special ball bearing, the hydraulic cylinders and pistons, the squeezing rollers and the operating valves. The troughs for the alkali and the wash-waters are situated inside the cast-iron frame. The bed-plate at the left end carries the pump for the alkali.

A special type of hydraulic motor coupled with yarn roller imparts forward-reverse rotations to the hank with two adjustable speeds.

A minor refinement is provided by three separate channels for the wash waters; the first is for the hot wash-water from the first rinse, which is relatively concentrated in NaOH and may be recovered, whereas the second hot rinsing water in more dilute in alkali, but, nevertheless, may be used in scouring or dyeing. The separation of the wash-waters is automatic.

The adjustment of the machine to suit the yarn is achieved quite simply by means of a display unit on the panel box. All three stages of tension can be set from the control panel in terms of percentage of total set pressure, which could be maximum 140 bars. The effect of tension on hank elongation can be observed from display unit in terms of cms., which facilitate required changes in tension value. The final elongation can be set with the help of hand wheel, which

restricts stretching beyond desired extent. All the parameters like tension value, tension time, shrinkage time, squeezing time, lye pump time, lye tray-water tray-time, roller cycle, hot water-cold water time, waste lye drainage cycle, dosing pump cycle, etc. can be set from display unit. Different recipes can be set and stored for different mercerizing parameters and can be recalled for the use. The different positions of various components are interlocked with the help of proximity switches ensures safe operation and maintenance of the machine.

One of the characteristic features of the machine is the disposition of the two pairs of rollers. They are permanently supported in the middle frame and are also held in sliding supports with heavy ball bearings at both ends when in the horizontal working position; this enables high stretching pressures to be employed uniformly along the whole length of the rollers.

The pairs of rollers oscillate from the charging position (vertical and above the body) to the working position (horizontal and below the body). The useful length of the rollers is 108 cms. and the thickness of some three kgs. of yarn is distributed along this length, and by stretching and squeezing is so reduced as to minimize to a great extent the difference between external and internal circumferences of the hanks. The stretching force is 18000 kgf per machine and the squeezing force is 3200 kgs. Stretching and squeezing are effected hydraulically, and the raising and lowering of the oscillating body with the pairs of rollers is carried out automatically.

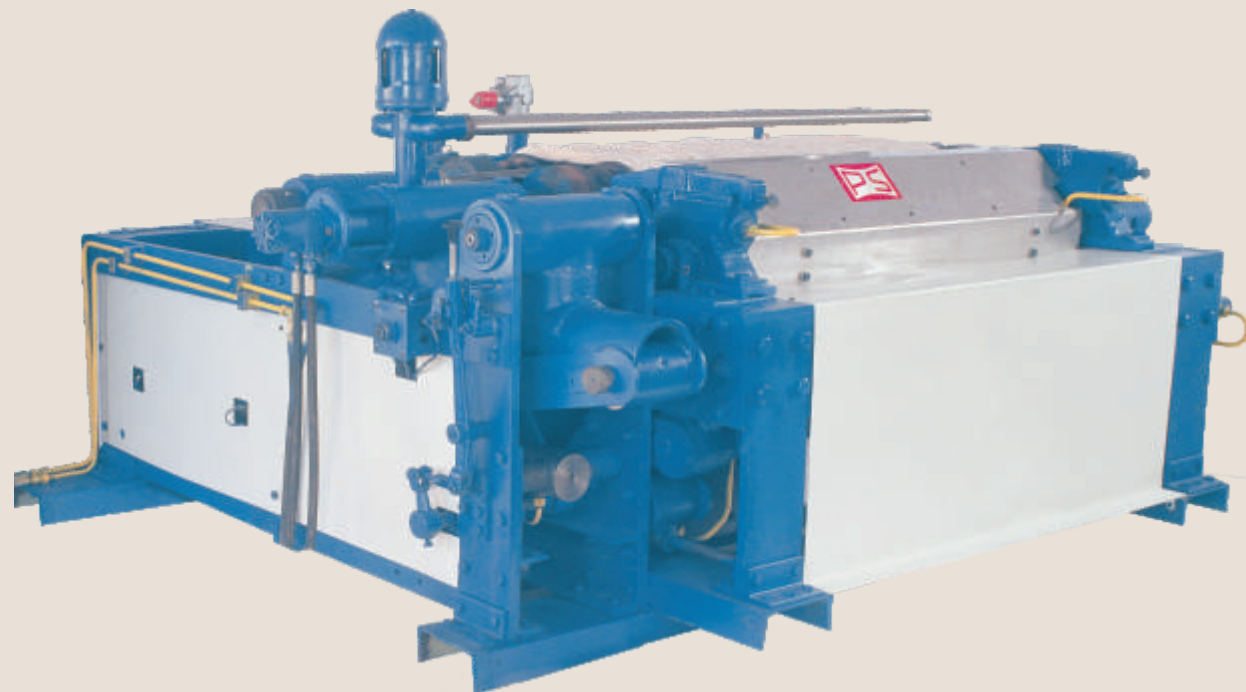

The cycle of operations may best be followed from the first preliminary stretching, when the yarn is dipped in the alkali and impregnated on the whole circumference with the rollers running at high speed. The yarn is then allowed to shrink and the speed of the roller changes to slow; the hanks are then stretched to the predetermined desired extent.

The alkali is continuously renewed in the basins or troughs during these three operations. The next step is to squeeze out the alkali back to the tank in the floor. The troughs for the alkali are then lowered and those for the rinsing water are brought into position.

The hot rinsing water is applied from spurt pipes and the first rinsing water is separated from the rest. After washing with cold water, the hanks are squeezed with the rollers running at high speed; they are then raised to the charging position and the distance between them is reduced. The machine then stops

and the yarn is removed. The attendant, who slides the hanks from the swiveled arms of the hank pins at each side of the machine with the assistance of a special shovel, places a fresh charge of yarn on the rollers.

In the meantime, the rinsing trough is lowered and the alkali trough raised and filled with fresh liquor. The rollers are then lowered into the working position and the preliminary stretching starts.

The yarn is in contact with the alkali for about two minutes, and during the high speed rotation of the hanks during the first minute there are two changes in direction of rotation; this assists evenness of mercerizing.

The mercerizing cycle takes 270 seconds for three kgs. of yarn. The consumption of alkali is about 2 to 3 kgs. of NaOH per 10 kgs. of yarn.

Salient Features

- Entire machine is controlled by PLC controller
- With the help of user friendly MMI, mercerizing parameters can be kept as per requirement for different qualities of yarn
- Different recipes can be stored and retrieved at finger tips
- Oil based hydraulic system for smooth operation and no corrosion
- Automatic caustic lye concentration regulation + Auto Dosing System

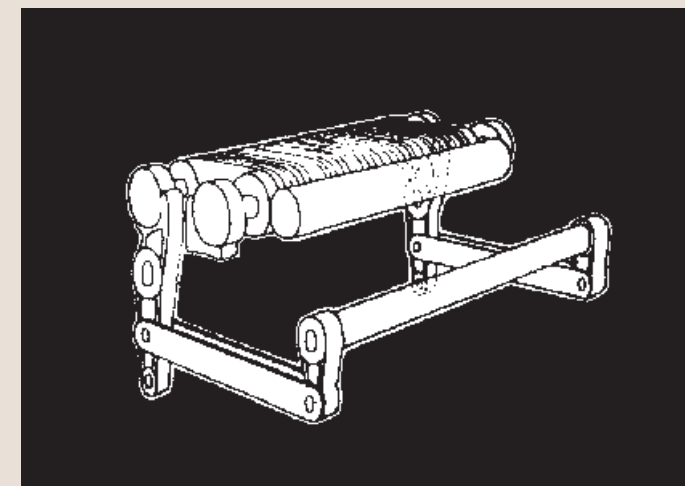

Diagrammatic representation of the hankroller bearings. Each end of the rollers has its stretching device, which are connected to each other by a torsion shaft. Strict parallelism of the hank rollers is therefore ensured.